

# SKF Cooper split bearings

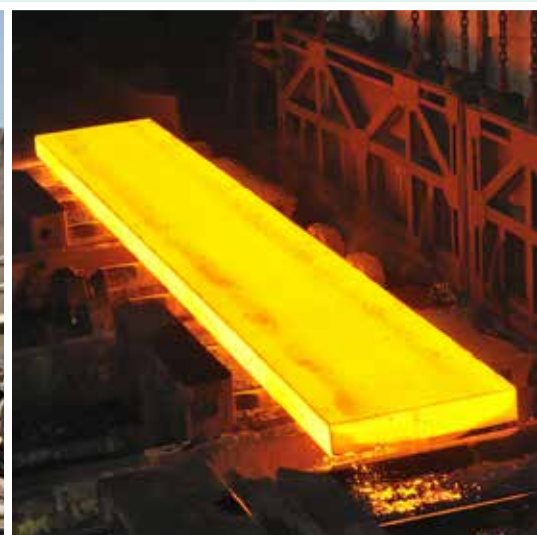

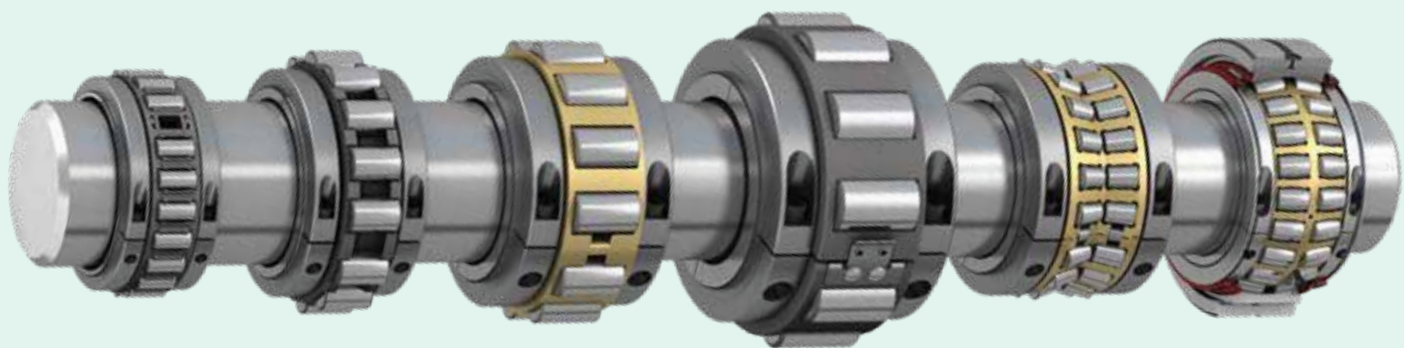

# The company

SKF Cooper is the leading supplier of split roller bearings, providing quality and long lasting products since 1907.

Based in the UK, SKF Cooper designs and manufactures bearings and bearing housings on the same site using the latest in cellular, flexible techniques and machinery.

Direct, specialised engineering support is available from our offices in the USA, Germany, India and Australia. Together with the local support and assistance of a global network of authorised distributors, our customers worldwide receive "First In Class" service and attention.



# The product

SKF Cooper split bearings are the ideal solution to reduce machinery maintenance and repair downtime.

The advantages of the SKF Cooper split bearing solution are especially valuable in inaccessible or trapped locations, for example, between head pulley and gearbox or motor, where the need to dismount associated equipment is eliminated.

Split bearings disassemble into smaller components easing the tasks of lifting and handling and making mounting or replacement simple even in the most cramped and inaccessible conditions.

Clearances are pre-set, so no on-site adjustment is needed and no specialized fitting tools are required.

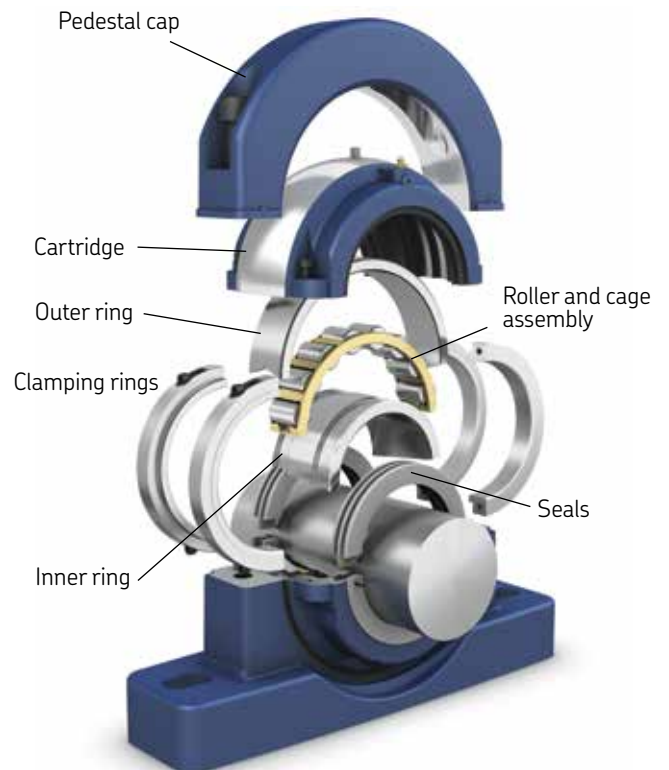

# Bearing series

SKF Cooper provides the widest assortment on the market. It includes four series of cylindrical roller bearings, two types of split tapered roller bearings, and new split spherical roller bearings\*

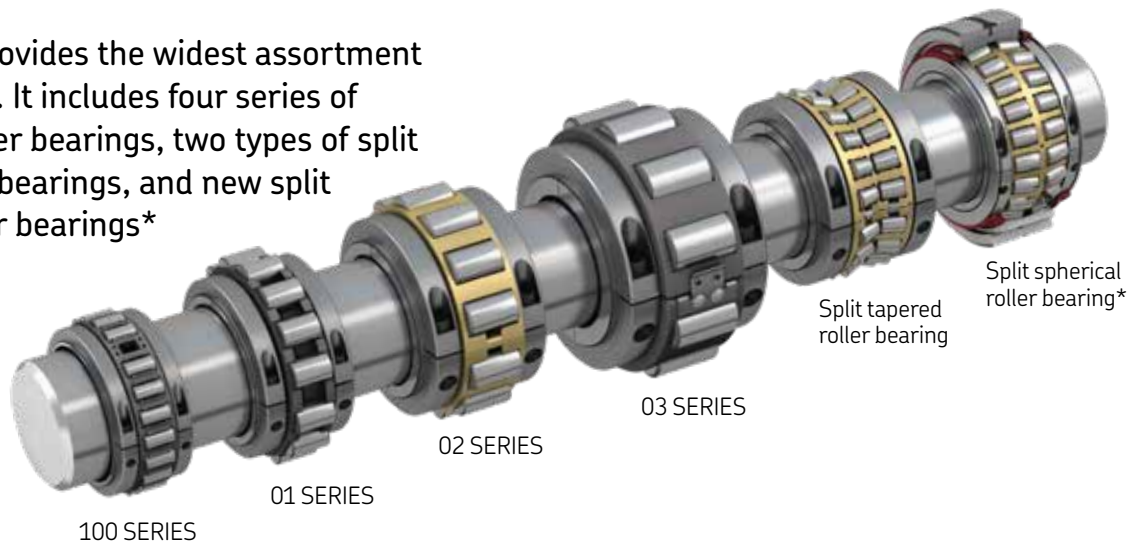

The standard assortment is available for bore sizes from 30 mm to 1 500 mm (1 1/4" to 59").

A comprehensive array of customisation options to the standard design is also available. These include special internal clearances, lip configurations etc.

\* for further details please refer to the split spherical roller bearing marketing material. The following housing, bearing and sealing types in this brochure are for the split cylindrical roller and split taper roller bearing series.

# Housing types

We are the only manufacturer of split bearings to have our own integrated foundry, which allows us to provide the highest quality bearings and housings.

Housings are manufactured and machined in a variety of configurations and in a variety of materials, for example; grey cast iron grade 250, nodular iron, steel, aluminium and stainless steel.

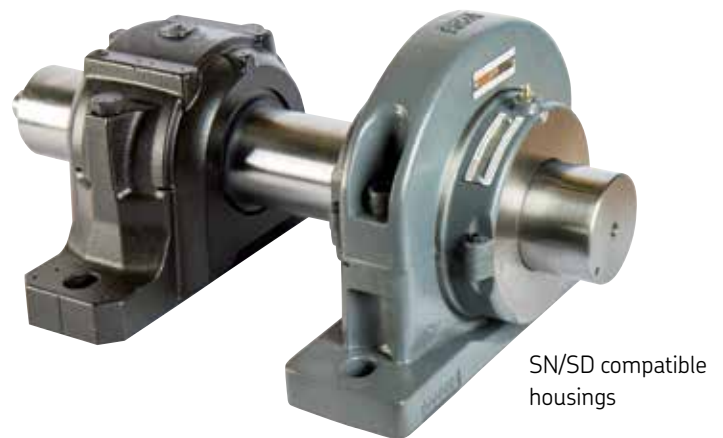

Hanger units

Round flanged units

Large bore base units

Two bolt base units

Rod end units

Square flanged units

Take-up units

# Bearing types

## Expansion (EX)

The inner ring is clamped to the shaft, and moves axially with it when expansion or contraction occurs. The SKF Cooper expansion bearings offer virtually no resistance to axial movement as the rollers spiral through the outer ring raceway.

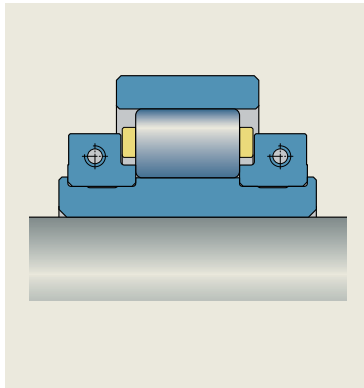

## Fixed (GR)

Provides axial location to the rotating elements of machinery. Can accommodate axial and radial loads.

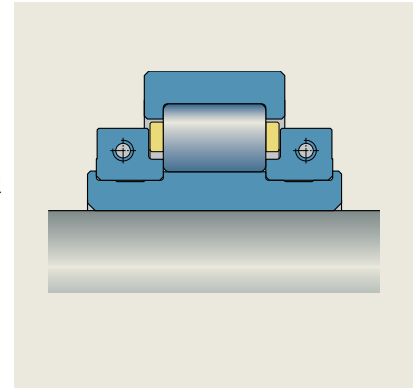

# Sealing types

**Superior performance and extended bearing service life by preventing contaminants from entering the bearing.**

Due to the external alignment via the seal-carrying cartridge, seals on SKF Cooper bearings work perpendicular to the shaft, providing optimum protection from potential damage from abrasive materials such as cement or sugar.

SKF Cooper offers a wide assortment of sealing solutions to suit different requirements and operating environments.

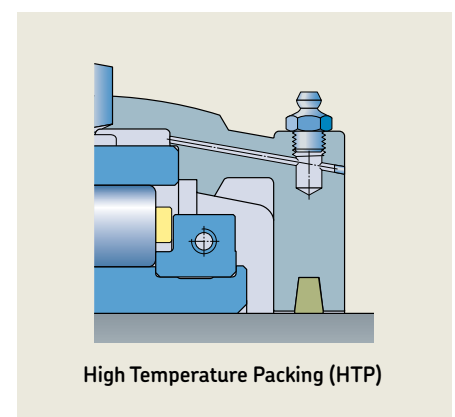
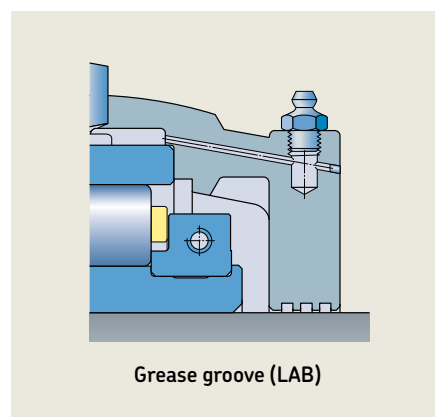
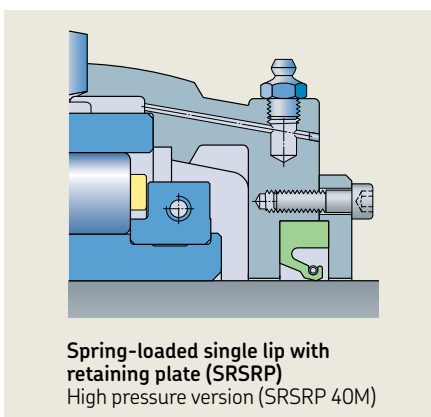
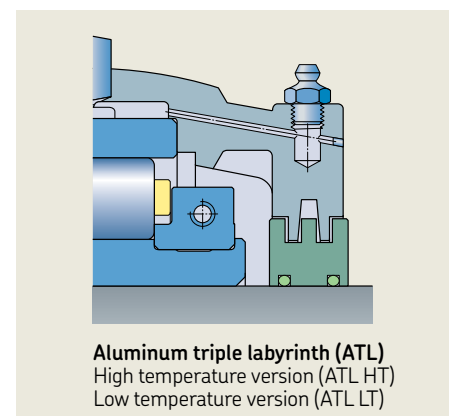
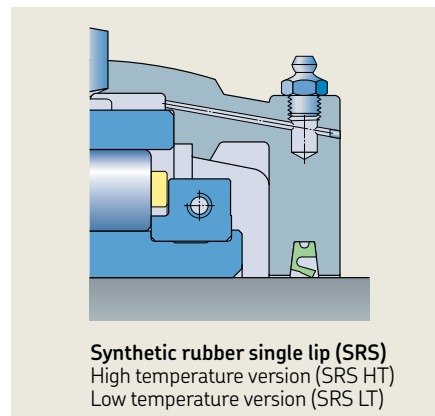
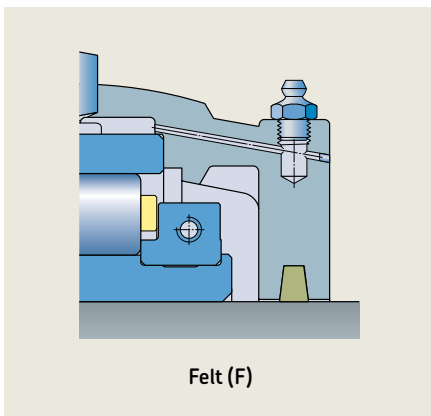

# Applications

SKF Cooper split roller bearings are used across a variety of industries and applications. Key advantages are ease of mounting, inspection and replacement, as well as the superior effectiveness of the sealing system in the most adverse environments.



## Belt conveyor

In trapped locations such as this, split bearings provide significant savings in maintenance and downtime, due to the elimination of the need to dismount and refit important associated components.



## Belt conveyor

The pedestal unit in a trapped position on a cement conveyor graphically illustrates how the effective sealing system can provide long bearing service life in the most adverse environments.



## Fans

Split to the shaft bearings provide increased savings in downtimes in the paint shop of a UK car plant.



## Fans

The split to the shaft solutions eliminate the need to dismount associated components. Combined with the frictionless expansion accommodated by EX bearings, the split solution is ideal on long drive shafts or hot gas fans.



## Screw conveyor

Solving the problems of shaft wear and product contamination from oil and corrosion from the use of sleeve bearings. A custom-built solution combined a triple boss hanger mounting with split roller bearings equipped with double sealing and air purge provision on each end.



## Screw conveyor

Cleanliness requirements during the final stage of transport of white sugar to the bagging area advocated the use of a custom-built 100 mm stainless steel hanger unit.



### Bucket elevator

The SKF Cooper flanged unit at a grain plant illustrates the advantages of split to the shaft solutions when performing maintenance tasks in cramped and inaccessible locations.



### Bucket elevator

Bucket elevator with 01 BCP 160 mm GR in trapped position for easier, cost-saving maintenance.



### Stacker reclaimers

The slewing ring pinion gear is supported by 6 1/2 inch and 7 inch 01 Series SKF Cooper bearing in flange housings. SKF Cooper bearings up to 380 mm in diameter are used on the shaft of the bucket wheel as shown.



### Ball mills

01 BCP 1016 mm EXILOG GR fitted to a 10 feet diameter Silica Mill. Split roller bearings offer considerable power savings compared to sleeve bearings.



### Water turbine

01 BCF 380 mm EX was selected in conjunction with the OEM on this 11 000 kW vertical shaft 'Kaplan' turbine. Our product was chosen because of the simplified installation, inspection and maintenance.



### Wind energy test rig

Split roller bearings offer shaft tolerance and energy consumption advantages compared to hydrodynamic sleeve bearings.



### Marine propulsion

The ideal alternative to sleeve bearings for propeller shafts and water jets, split to the shaft bearings eliminate complex oil-feed systems.



### Pilger mills

Our product offers extended bearing service life in this most demanding of applications.

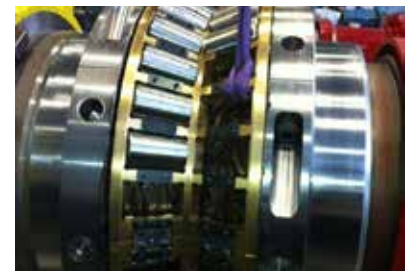

### Link spindles

Cooper double row 780 mm bore split tapered roller bearing on a link spindle for a rolling mill drive.

**SKF (U.K.) Limited**

Sundon Park Road, Luton,  
Bedfordshire LU3 3BL

**T:** 01582 490049

**F:** 01582 848091

marketing.uk@skf.com

[skf.co.uk](http://skf.co.uk) | [cooperbearings.com](http://cooperbearings.com)

© SKF and Cooper are registered trademarks of the SKF Group.

© SKF Group 2019

The contents of this publication are the copyright of the publisher and may not be reproduced (even extracts) unless prior written permission is granted. Every care has been taken to ensure the accuracy of the information contained in this publication but no liability can be accepted for any loss or damage whether direct, indirect or consequential arising out of the use of the information contained herein.

PUB BU/P2 17589 EN · July 2019

Certain image(s) used under license from Shutterstock.com.