

# 143 EEX gerotor pump unit

For use in oil circulation systems in gas- and dust-Ex-atmospheres



# Gerotor pump series 143 EEX

The 143 EEX product series has been specifically designed for centralized lubrication systems in explosive environments. It offers a high degree of protection in a gas or dust explosive atmosphere.

The 143 EEX series is a complete pumping unit solution including pump, motor, coupling and sealing all according to ATEX requirements. It is based on the well-proven and established SKF 143 gerotor pump series. It feeds the lubricating oil from a reservoir into the pipe system of an oil lubrication system.

The 143 EEX is a self-priming positive-displacement pump with high efficiency and one delivery circuit. The annular-toothed feeding element, also referred to as the gerotor, is equipped with a cycloid contour, which creates a large tooth meshing length. This yields a low volumetric flow pulsation and thus very smooth running, low noise production, and good suction characteristics.

## Features and benefits:

- Reliable and safe operation in explosive environments (Zone 1, 2, 21, 22)
- Low volumetric flow pulsation allows very smooth running
- Gerotor with a cycloid contour provides optimum suction characteristics
- Low noises during operation
- Large viscosity range for standard mineral and synthetic lubricating and hydraulic oils
- Compact design with pump, motor, coupling and seal
- Durable and rugged gerotor pump unit



## Explosion protection:

### ATEX

- ATEX II 2G c IIC T4 Gb
- ATEX II 2D c IIIC T120°C Db

### IECEx (motor only)

- Ex de IIC T4 Gb
- Ex tb IIIC T120°C Db

## Further information

Brochure **PUB 17160**  
 Assembly instructions **951-180-074**

You can download the publications as PDF file from the SKF website [skf.com/143](http://skf.com/143)

Online configurable under [skf-lubrication.partcommunity.com](http://skf-lubrication.partcommunity.com)

Table 1

## Technical data

Lubricant	standard mineral, synthetic lubricating and hydraulic oils	
Viscosity	20–1 000 mm <sup>2</sup> /s	
Flow range	0,85–50 l/min	0,22–13 gal/min
Operating pressure	up to 50 bar	up to 725 psi
Operating temperature	0 to +40 °C	+32 to 104 °F
Lubricant temperature	0 to +60 °C	+32 to 140 °F
Protection class	IP 54	
Drive speed depending on design	1 400 and 2 800 r/min	
Suction head, max.	1000 mm	
Varnishing	RAL 7024 graphite grey, special painting optional	
Duty type per VDE	0530 S1	
Sealing material	FKM	
Mounting position	horizontal, vertical	
ATEX classification for gas	II 2G c IIC T4 Gb	
ATEX classification for dust	II 2D c IIIC T120°C Db	
<b>Materials</b>		
Pump housing	hydraulic cast (pressure-proof) with good wear and antifriction properties	
Gerotor insert	sintered material	
Shafts	low-deformation case-hardened steels	
Bearing	SKF plain bearing	

Typical layout of an oil-circulation system

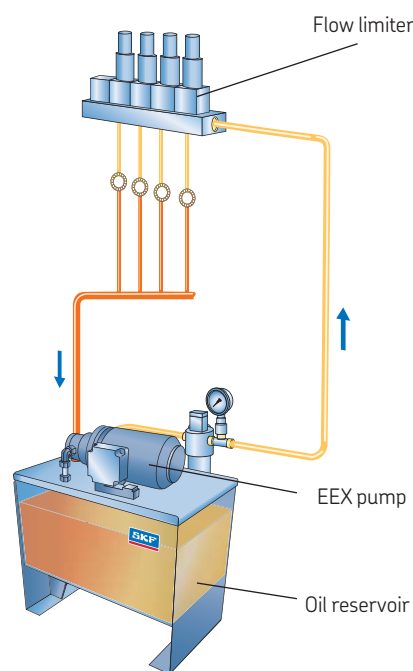

# Gerotor pump series 143 EEX

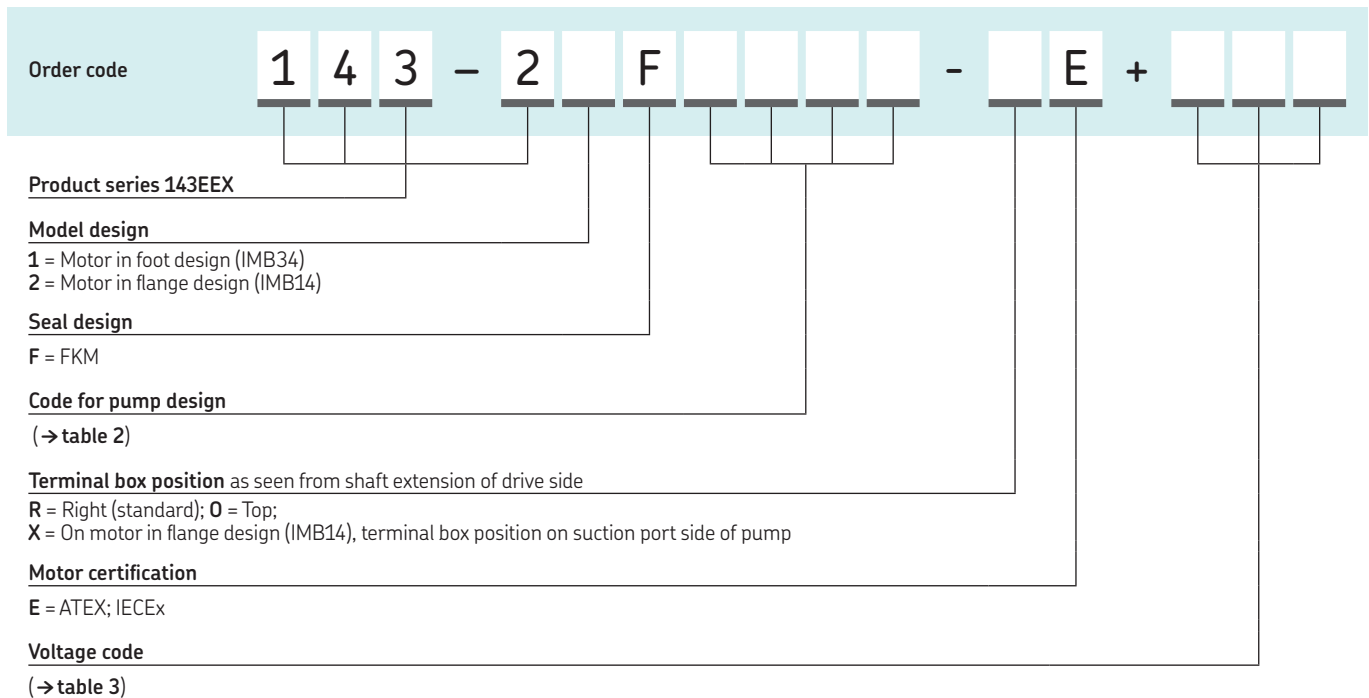

Table 2

Code for pump design								
Code	Nominal delivery rate		Back pressure max.		Motor drive power	Permissible operating viscosity	Frame size	Number of poles
	l/min	gal/min	bar	psi	kW	mm <sup>2</sup> /s	–	–
B03D	0,85	0.22	30	435	0,25	20–1000	71	4
D03E	1,70	0.45	30	435	0,37	20–1000	71	2
F02D	2,50	0.66	20	290	0,25	20–1000	71	4
F05F	2,50	0.66	50	725	0,55	20–1000	80	4
H02F	5,25	1.39	20	290	0,55	20–1000	80	4
H05J	5,25	1.39	50	725	1,10	20–1000	90	4
K02H	9,00	2.38	20	290	0,75	20–1000	80	4
K05K	9,00	2.38	50	725	1,50	20–1000	90	4
M02H	12,50	3.30	20	290	0,75	20–1000	80	4
M05L	12,50	3.30	50	725	2,20	20–1000	100	4
P02L	19,00	5.02	20	290	2,20	20–1000	100	4
R02M	30,00	7.93	20	290	3,00	20–1000	100	2
R03M	30,00	7.93	30	435	3,00	20–750	100	2
R03N	30,00	7.93	30	435	4,00	20–1000	112	2
T02M	40,00	10.57	20	290	3,00	20–750	100	2
T03N	40,00	10.57	30	435	4,00	20–1000	112	2
V02N	50,00	13.21	20	290	4,00	20–1000	112	2
V03N	50,00	13.21	30	435	4,00	20–750	112	2
V03P	50,00	13.21	30	435	5,50	20–1000	132	2

Table 3

Voltage code	
Code	Motor power
+1GP	220 / 380 V, 50 Hz ; 255 / 440 V, 60 Hz
+1GD	230 / 400 V, 50 Hz ; 265 / 460 V, 60 Hz
+1GQ	240 / 415 V, 50 Hz ; 280 / 480 V, 60 Hz
+1HQ	290 / 500 V, 50 Hz ; 330 / 575 V, 60 Hz
+1GH <sup>1)</sup>	380 / 660 V, 50 Hz ; 440 V, 60 Hz
+1GK <sup>1)</sup>	400 / 690 V, 50 Hz ; 460 V, 60 Hz
+1GL <sup>1)</sup>	415 V, 50 Hz, Δ; 480 V, 60 Hz, Δ
+1KG <sup>1)</sup>	400 V, 50 Hz, Δ; 460 V, 60 Hz, Δ
+1GF	200 / 345 V, 50 Hz
+1GG	200 / 345 V, 60 Hz
+MDP	220 / 380 V, 60 Hz
+1GR	230 / 400 V, 60 Hz

1) Motor power P ≥ 5,5 kW

# Gerotor pump series 143 EEX

## Foot and flange designs, technical data and dimensions

Figure 1

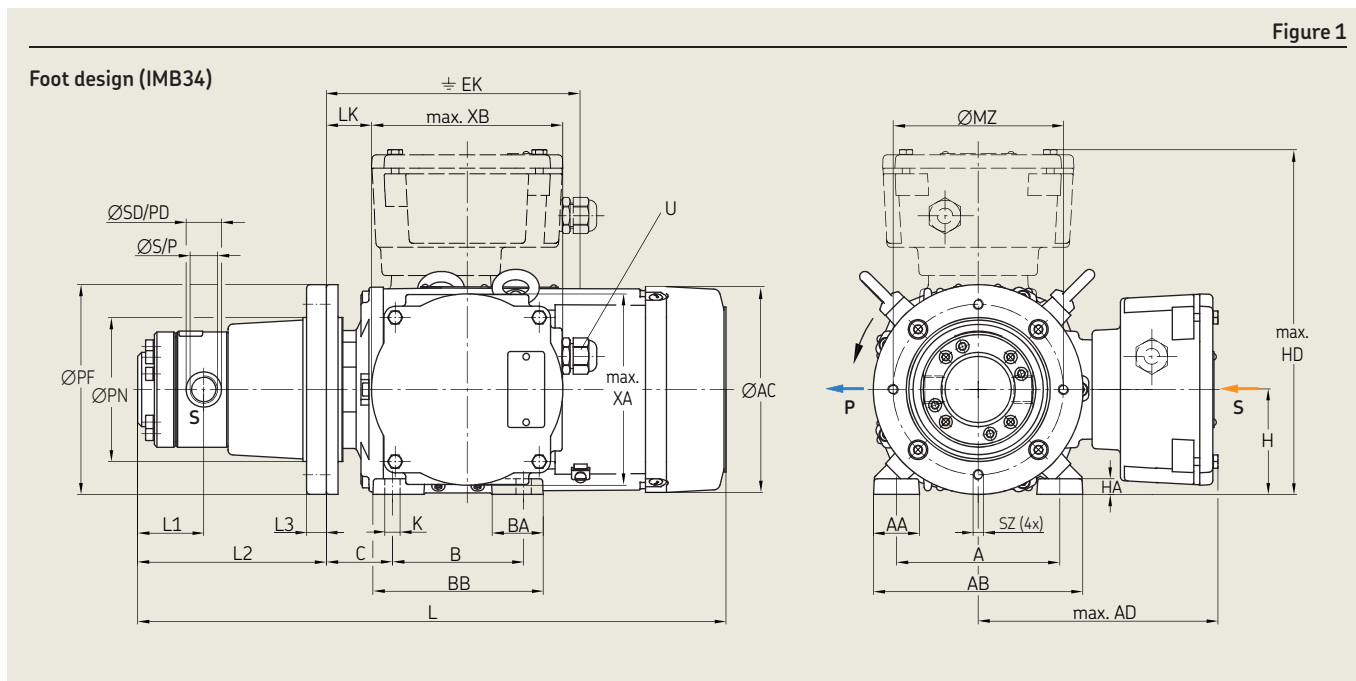

Nominal delivery rate [l/min]	Back pressure max. [bar]	Permis. viscosity range [mm <sup>2</sup> /s]	Char. curve No. <sup>1)</sup>	Nominal output [cm <sup>3</sup> /rev.]	Suction port S	Pressure port P	Weight Foot design [kg]	Flange design [kg]	Dimensions [mm] (→ Fig. 1+2)						
									ØPD	ØSD	ØPN	ØPF	ØFM1	ØMZ	ØM1
0,85	30	20–1000	1	0,61	G1/4 12 deep	G1/4 12 deep	20	20	19	95	140	–	115	–	M8
1,7	30	20–1000	2	0,61	G1/4 12 deep	G1/4 12 deep	21	20	19	95	140	–	115	–	M8
2,5	20	20–1000	3	1,79	G3/8 12 deep	G3/8 12 deep	21	21	23	95	140	–	115	–	M8
2,5	50	20–1000	3	1,79	G3/8 12 deep	G3/8 12 deep	28	28	23	110	160	–	130	–	M8
5,25	20	20–1000	4	3,75	G1/2 14,5 deep	G1/2 14,5 deep	29	29	27	110	160	–	130	–	M8
5,25	50	20–1000	4	3,75	G1/2 14,5 deep	G1/2 14,5 deep	45	45	27	110	160	–	130	–	M8
9	20	20–1000	5	6,44	G1/2 14,5 deep	G1/2 14,5 deep	37	37	27	110	160	–	130	–	M8
9	50	20–1000	5	6,44	G1/2 14,5 deep	G1/2 14,5 deep	49	48	27	110	160	–	130	–	M8
12,5	20	20–1000	6	8,93	G3/4 16 deep	G3/4 16 deep	37	37	33	110	160	–	130	–	M8
12,5	50	20–1000	6	8,93	G3/4 16 deep	G3/4 16 deep	62	62	33	110	160	–	130	–	M8
19	20	20–1000	7	13,6	G1 18 deep	G1 18 deep	62	62	40	110	160	–	130	–	M8
30	20	20–1000	8	10,74	G1 18,5 deep	G1 18,5 deep	63	63	41	144,6	200	250	165	225	–
30	30	20–750	8	10,74	G1 18,5 deep	G1 18,5 deep	63	63	41	144,6	200	250	165	225	–
30	30	20–1000	8	10,74	G1 18,5 deep	G1 18,5 deep	83	83	41	144,6	200	250	165	225	–
40	20	20–750	9	14,36	G1 18,5 deep	G1 18,5 deep	63	63	41	144,6	200	250	165	225	–
40	30	20–1000	9	14,36	G1 18,5 deep	G1 18,5 deep	83	83	41	144,6	200	250	165	225	–
50	20	20–1000	10	17,87	G1 1/4 20,5 deep	G1 18,5 deep	83	84	41	144,6	200	250	165	225	–
50	30	20–750	10	17,87	G1 1/4 20,5 deep	G1 18,5 deep	83	84	41	144,6	200	250	165	225	–
50	30	20–1000	10	17,87	G1 1/4 20,5 deep	G1 18,5 deep	115	114	41	145	200	250	165	225	–

<sup>1)</sup> → see page 6

# Gerotor pump series 143 EEX

## Foot and flange designs, technical data and dimensions

Figure 2

### Flange design (IMB14)

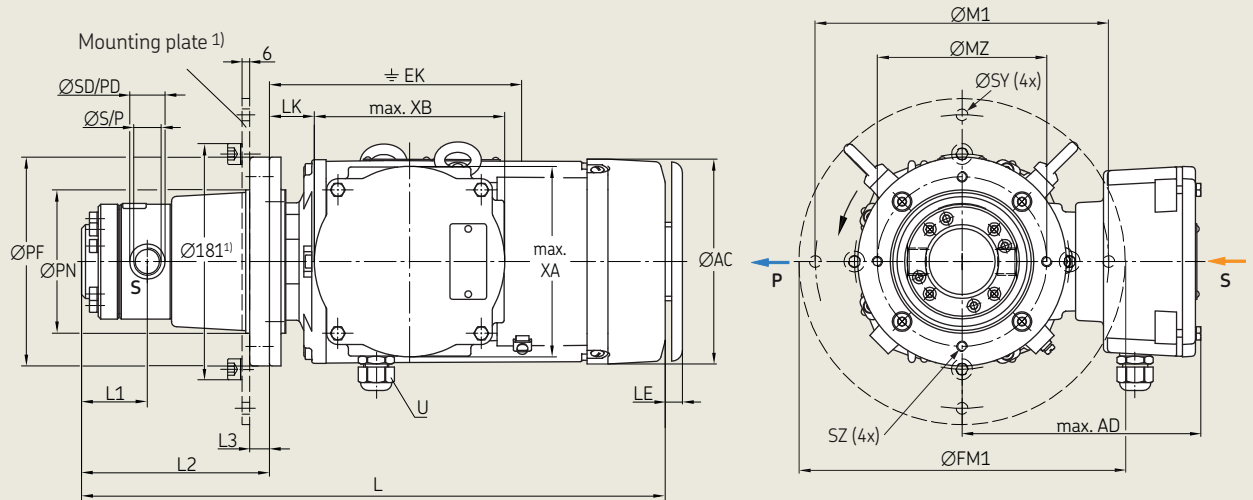

1) Mounting plate only for delivery rate 30, 40, and 50 l/min.

Table 4

### Dimensions [mm] (→ Fig. 1+2)

	ØSY	L1	L2	L3	A	AA	AB	ØAC	AD	B	BA	BB	C	H	HA	HD	K	L	LE	LK	EK	U	XA XB
-	36,5	109	12	112	30	139	145	164	90	25	110	45	71	10	235	7	357	25	28	84	1xM5		145
-	36,5	109	12	112	30	139	145	164	90	25	110	45	71	10	235	7	357	25	28	84	1xM5		145
-	45	127	17	112	30	139	145	164	90	25	110	45	71	10	235	7	375	25	28	84	1xM5		145
-	45	137	15	125	35	160	163	180	100	35	130	50	80	12	260	10	410	25	23	2)	1xM5		145
-	50,5	144	15	125	35	160	163	180	100	35	130	50	80	12	260	10	417	25	23	2)	1xM5	2x M25x1,5	145
-	50,5	153	17	140	40	180	178	198	125	40	155	56	90	12	288	10	501	25	36	226	1xM5		145
-	57	152	15	125	35	160	158	185	100	37	130	50	80	12	265	10	455	25	34	193	1xM5		145
-	57	161	17	140	38	180	178	198	125	44	155	56	90	12	288	10	509	25	36	226	1xM5		145
-	67	164	15	125	35	160	158	185	100	37	130	50	80	12	265	10	467	25	34	193	1xM5		145
-	67	198	17	160	42	200	198	205	140	46	175	63	100	15	305	12	557	30	41	250	1xM5		145
-	75	209	17	160	42	200	198	205	140	46	175	63	100	15	305	12	568	30	41	250	1xM5		145
9	78	218	16	160	42	200	198	205	140	46	175	63	100	15	305	12	577	30	41	250	1xM5		145
9	78	218	16	160	42	200	198	205	140	46	175	63	100	15	305	12	577	30	41	250	1xM5		145
9	78	218	16	190	45	235	218	225	140	46	175	70	112	17	337	12	675	30	76	100	2xM5	1x M25x1,5	145
9	78	218	16	160	42	200	198	205	140	46	175	63	100	15	305	12	577	30	41	250	1xM5	1x M32x1,5	145
9	78	218	16	190	45	235	218	225	140	46	175	70	112	17	337	12	675	30	76	100	2xM5		145
9	81	221	16	190	45	235	218	225	140	46	175	70	112	17	337	12	678	30	76	100	2xM5		145
9	81	221	16	190	45	235	218	225	140	46	175	70	112	17	337	12	678	30	76	100	2xM5		145
9	81	251	16	216	60	266	265	279	140	60	187	89	132	20	411	12	700	30	36	279	2xM5	2x M25x1,5 1x M32x1,5	220

2) EK = 104 for terminal box position on top and type IMV18  
EK = 193 for terminal box position on right or left

# Gerotor pump series 143 EEX

## Characteristic curves

Diagram 1

Operating viscosity 20 mm<sup>2</sup>/s, 50 Hz

Delivery rate Q [l/min]

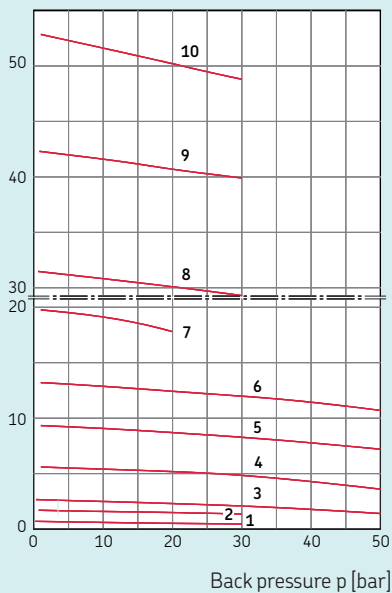

Diagram 2

Operating viscosity 140 mm<sup>2</sup>/s, 50 Hz

Delivery rate Q [l/min]

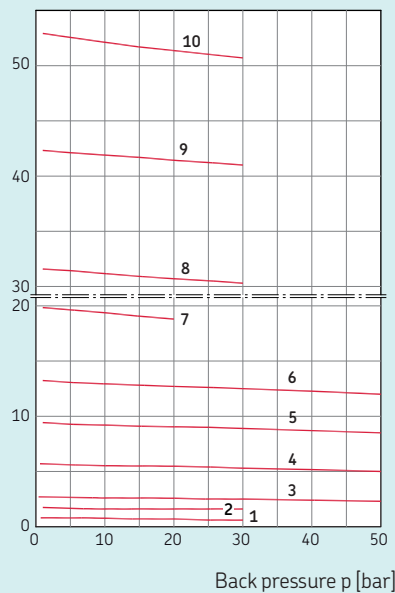

Diagram 3

Operating viscosity 750 mm<sup>2</sup>/s, 50 Hz

Delivery rate Q [l/min]

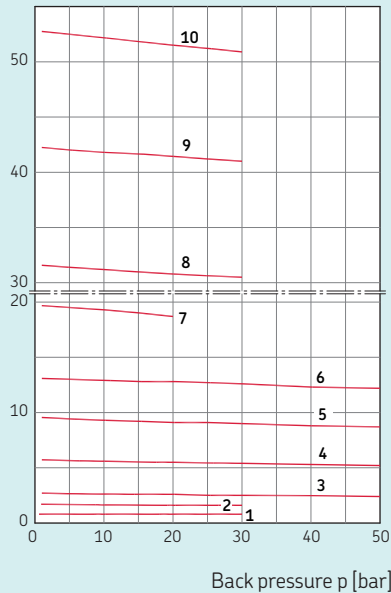
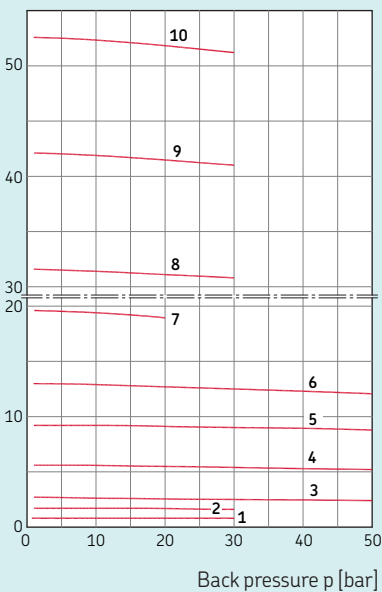

Diagram 4

Operating viscosity 1000 mm<sup>2</sup>/s, 50 Hz

Delivery rate Q [l/min]



### Legend to diagram 1-4:

- Characteristic curve 1: 0,85 l/min
- Characteristic curve 2: 1,7 l/min
- Characteristic curve 3: 2,5 l/min
- Characteristic curve 4: 5,25 l/min
- Characteristic curve 5: 9 l/min
- Characteristic curve 6: 12,5 l/min
- Characteristic curve 7: 19 l/min
- Characteristic curve 8: 30 l/min
- Characteristic curve 9: 40 l/min
- Characteristic curve 10: 50 l/min

Tolerances according to VDMA 24284-II

For connection with a frequency of 60 Hz, the speed and the volumetric flow are increased by 20% (compared to the table specifications, basis 50 Hz).

# SKF CircOil EEX systems

## Reliable operation in challenging environments

SKF CircOil systems circulate oil to lubricate and cool bearings in many industrial applications. They also efficiently remove dirt, water and air particles. This cooling effect becomes especially important in explosive atmospheres. Friction, wear and contamination can lead to overheating and bearing failures.

This creates a potential ignition source and risk zone. SKF offers a range of CircOil EEX pumps, metering devices such as the SKF flow limiters and systems that help to ensure reliable safety in your operations. All products were designed to provide a high degree of safety in gas- and dust-Ex-atmospheres.

## Application areas with explosive gas or dust:

- Oil and gas industry
- Energy generation
- Chemical and pharmaceutical industries
- Food and beverage
- Agriculture
- Wastewater
- Marine
- Heavy industry
- Machine tool industry
- Wood industry

## SKF CircOil EEX Benefits:

- Safe operation in explosive environments
- Efficient cooling and lubrication
- Increased machine reliability and reduced downtime
- Many customizable solutions available
- Demand-based distribution of lubricant
- Efficient visual and electronic monitoring options
- Prolonged oil life thanks to patented air-removal design
- Reduced oil purchasing, handling and disposal costs

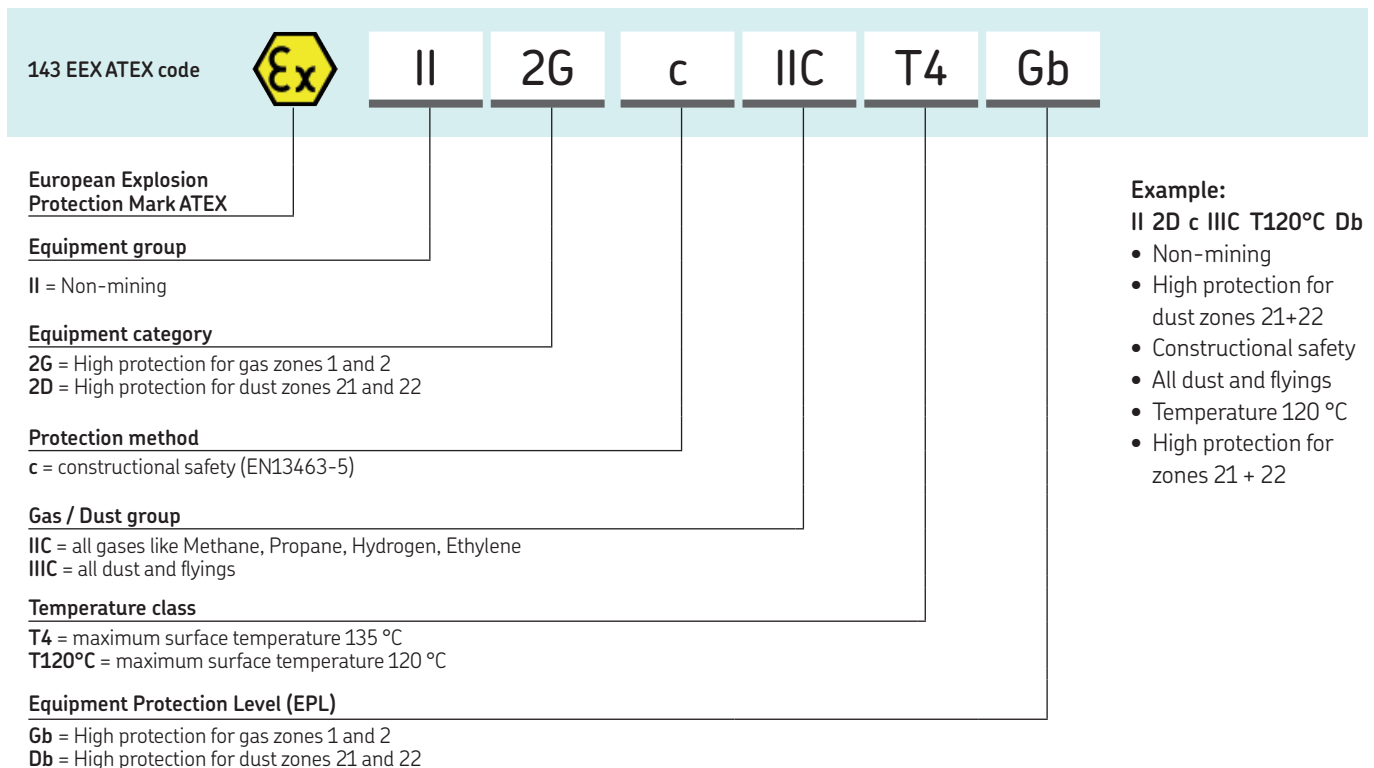



#### **Important information on product usage**

SKF and Lincoln lubrication systems or their components are not approved for use with gases, liquefied gases, pressurized gases in solution and fluids with a vapor pressure exceeding normal atmospheric pressure (1 013 mbar) by more than 0,5 bar at their maximum permissible temperature.



[skf.com](http://skf.com) | [skf.com/lubrication](http://skf.com/lubrication) | [skf.com/143](http://skf.com/143)

© SKF is a registered trademark of the SKF Group.

© SKF Group 2017

The contents of this publication are the copyright of the publisher and may not be reproduced (even extracts) unless prior written permission is granted. Every care has been taken to ensure the accuracy of the information contained in this publication but no liability can be accepted for any loss or damage whether direct, indirect or consequential arising out of the use of the information contained herein.

PUB LS/P2.17345 EN · May 2017