

Cycle switches, cycle indicators, crossporting bars, overpressure indicators, rupture discs

# Accessories for Progressive Systems

For oil, grease and fluid grease

For use in SKF ProFlex progressive centralized lubrication systems

Progressive feeder with cycle switch



Electric overpressure indicator



Spray nozzle



SKF ProFlex systems are designed for small and medium-sized machines. They are used, for example, in the printing industry, construction machines, industrial presses and wind turbines. A feed pump or flow limiter supplies lubricant to the distributor that serves each outlet progressively, with a defined amount of lubricant.

Each distributor outlet can also serve a secondary distributor that divides the amount into smaller portions for progressive delivery to their outlets. To control the system's function, only one metering piston has to be controlled on a frequency basis.

SKF ProFlex progressive lubrication systems are designed for up to 150 lubrication points with grease or oil. In combination with parallel flow limiters, they can serve up to one thousand lubrication points or even more with oil. SKF ProFlex includes a wide range of progressive distributors based on a block, segmental or modular design with 2 to 20 outlets, flow rates of 0,01 cm<sup>3</sup> to 6 000 cm<sup>3</sup>/min and system pressures as high as 300 bars.



# Index

Cycle switches (piston detectors) .....	3
Cycle switch with built-in microswitch .....	3
Crossporting bars .....	4
Cycle indicators .....	4
Electric overpressure switch with proximity switch (120 bar) .....	5
Electric overpressure switch with micro switch .....	5
Electric overpressure indicators .....	6
Practical example 1 (PPU-UES) .....	6
Practical example 2 (PPU-UES) .....	6
Overpressure indicators .....	7
Rupture discs .....	7
Retainer for rupture discs .....	7
Check valves .....	8
Spray nozzles for grease up to NLGI-Grade 2 .....	9
Pressure relief valve (PRV) .....	10

# Cycle switch (Piston detector)

24-01569-60...

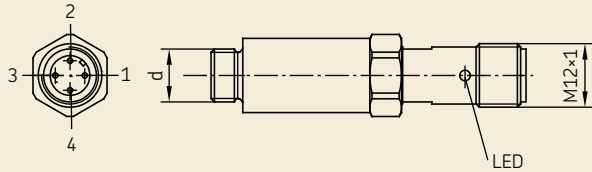

# Cycle switch with built-in micro switch

VP-ZYS

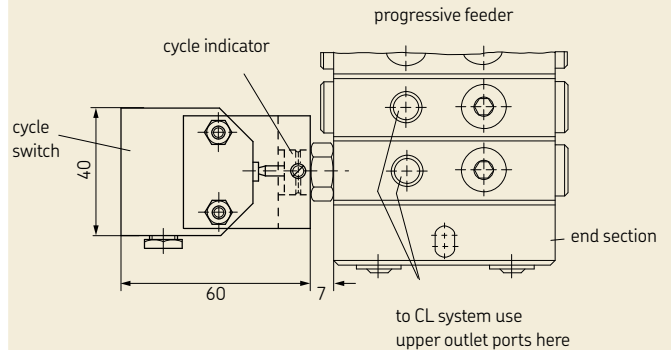

Table 1

Order No.	d	Feeder model	Version
24-0159-6021	M12x1	VP / PSG2	2-wire
24-0159-6022	M10x1	VPK / PSG1	2-wire
24-0159-6028	M10x1	VPB	2-wire
24-0159-6025	M12x1	VP / PSG2	3-wire
24-0159-6024	M10x1	VPK / PSG1	3-wire
24-0159-6023	M10x1	VPB	3-wire

Table 2

The unit is mounted on a feeder section with cycle indicator..

Order No.	Feeder model	Information
VP-ZYS <sup>1)</sup>	VP	The cycle switch can be used for all feeder sections starting at 2T. It is supplied detached.

<sup>1)</sup> state in order in addition to the feeder

## Technical data

Function . . . . .	NO contact
Operating voltage . . . . .	10 – 36 V DC
Current-carrying capacity . . . . .	100 mA
Operating temperature . . . . .	-40 bis +85 °C
Type of enclosure . . . . .	IP65; IP68; IP69 K
Housing material . . . . .	1.4571
Standard . . . . .	CE, UL, CSA, E1

## Technical data

Rated voltage . . . . .	230 V
Rated switching capacity . . . . .	230 V / 25 mA – 24 V / 2 A
Contact . . . . .	1 changeover
Type of enclosure (DIN 40050) . . . . .	IP 67
Type of connection . . . . .	soldered
Temperature range . . . . .	-5 to +80 °C

## CAUTION!

For all systems or components described in that brochure, see important product usage information on the back cover.

# Crossporting bars

Crossporting bars are used to combine adjacent outlet ports. They are screwed into the lateral outlet ports or, if on hand, into the upper alternative outlet ports.

**Table 3**

Order No.	Feeder model	Number of outlet ports to be combined
VP-C	VPM	2
VPG-C	VPG	2
VPBG(M)-C2	VPB	2
VPBG(M)-C3	VPB	3
VPBG(M)-C4	VPB	4
VPBM-C2-VS	VPB	2
VPBM-C3-VS	VPB	3
VPBM-C4-VS	VPB	4
24-2151-3732	PSG2	2
24-2151-3736	PSG3	2

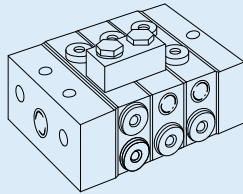

## VPBM-C3 / VPBG-C3

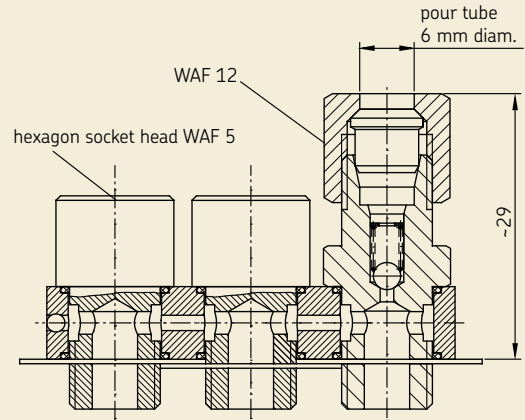

## VP-C / VPG-C

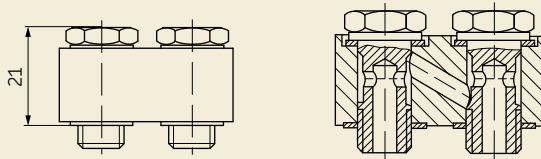

## VPBM-C3-VS for tube 6 mm diam. with plug-in connector

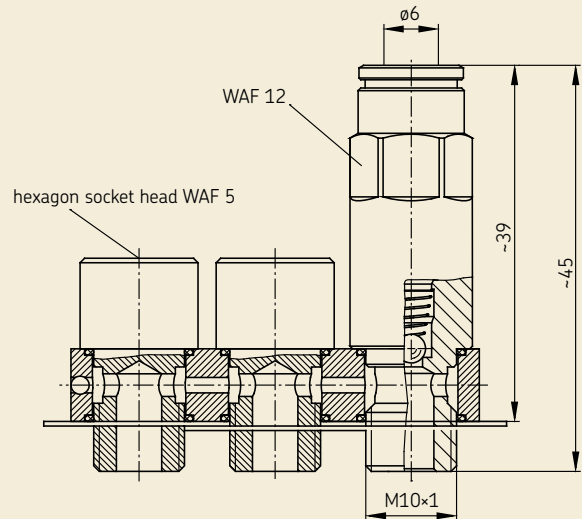

## 24-2151-3732 / 24-2151-3736

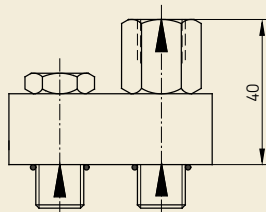

# Cycle indicators

Cycle indicators are used to monitor feeder functions. They are screwed into the piston bore of the first or last feeder section. In the course of each cycle, the display pin moves in and out. This motion does not take place if the feeder is blocked.

 The cycle switch is only available complete with feeder section.

## Cycle indicators

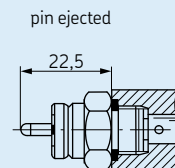
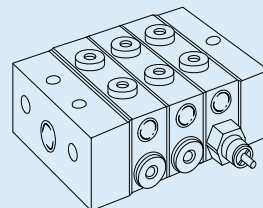

# Electric overpressure switch with proximity switch (120 bars)

# Electric overpressure switch with micro switch

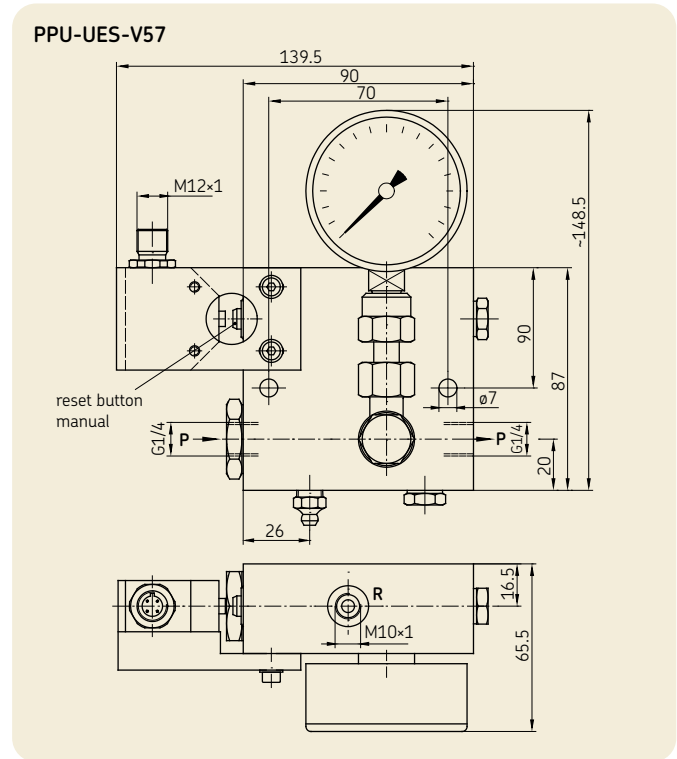
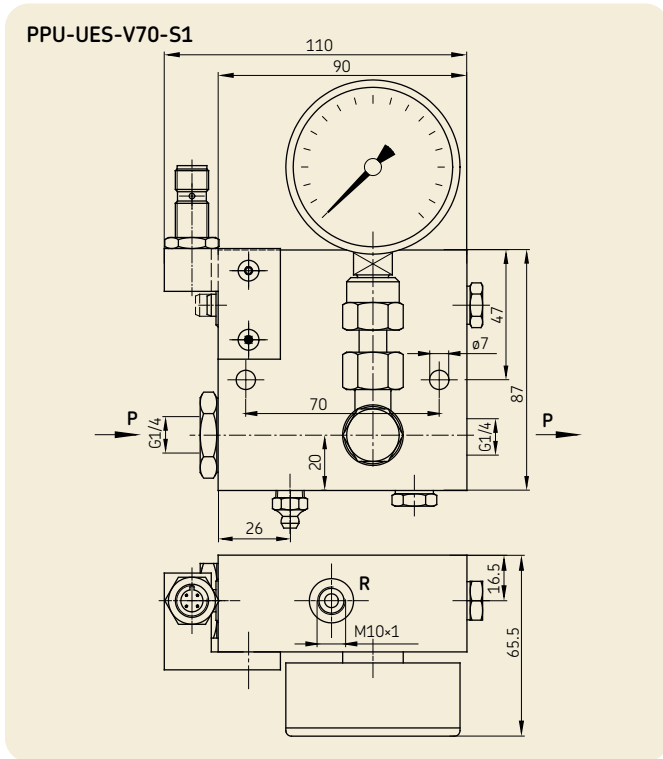

**Technical data**

Order No . . . . .	<b>PPU-UES-V70-S1</b>
Operating voltage . . . . .	10 ... 36 V DC
Current load . . . . .	100 mA max.
Contact . . . . .	NC type
Function indicate . . . . .	yellow (4x90°)
Type of enclosure (DIN 40050) . . . . .	IP 67
Temperature range . . . . .	-25 to +70 °C
Proximity switch . . . . .	adjusted to 120 bars

**Technical data**

Order No . . . . .	<b>PPU-UES-V57</b>
Rated voltage . . . . .	230V
Rated switching capacity . . . . .	230V / 25 mA – 24 V / 2 A
Contact . . . . .	1 changeover
Type of enclosure (DIN 40050) . . . . .	IP 67
Temperature range . . . . .	-5 to +80 °C

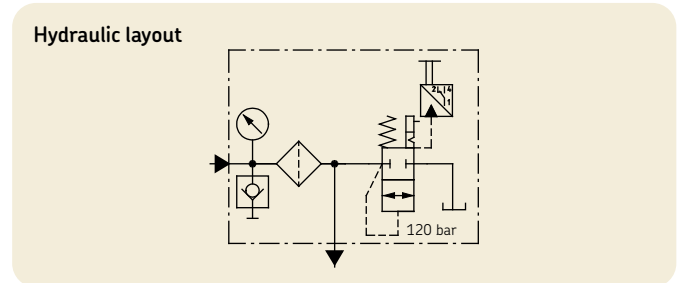
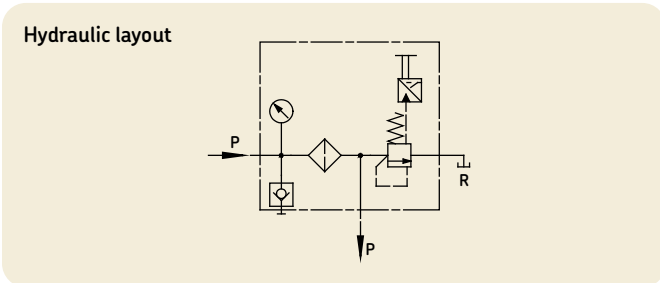
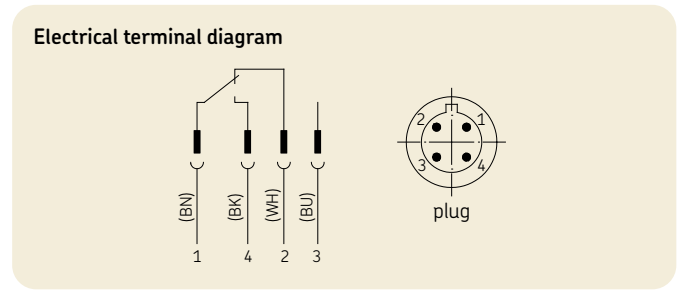
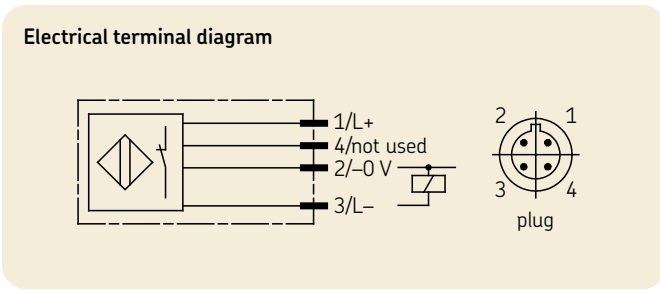

PUBLIS/P2.12005 EN · 1-0107-6-EN

# Electric overpressure indicator

PPU-UES

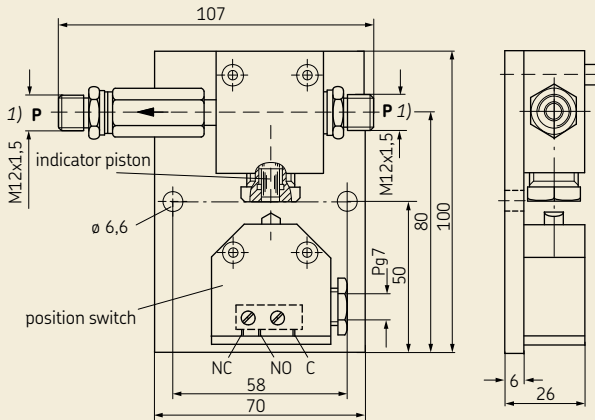

## Technical data

Order No. . . . . .	<b>PPU-UES</b>
Rated voltage . . . . .	230 V
Rated switching capacity . . . . .	230 V / 25 mA – 24 V / 2 A
Contact . . . . .	1 changeover
Type of enclosure (DIN 40050) . . . . .	IP 67
Type of connection . . . . .	soldered
Temperature range . . . . .	–5 to +80 °C

## Practical example 1 (for PPU-UES)

### Hydraulic layout

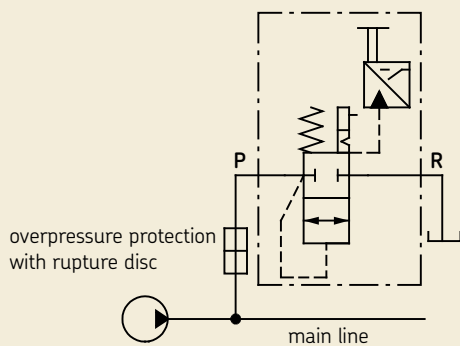

A rise in the system's pressure (malfunction) beyond the specified value destroys the rupture disc. The lubricant pushes the indicator piston out, resulting in the limit switch being actuated. The latter emits an electrical signal for acoustic or visual indication. But it can also be used to switch off the machine.

After the malfunction has been remedied and the rupture disc replaced, the indicator piston has to be pressed in again by hand.

## Practical example 2 (für PPU-UES)

### Hydraulic layout

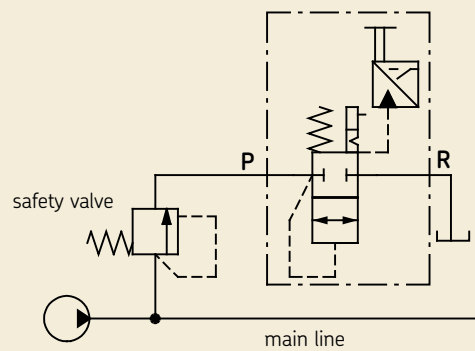

Functions like example 1, but the rupture disc does not have to be replaced since it is not destroyed and the safety valve automatically closes again when the specified pressure is restored. The indicator piston has to be pressed in again as in example 1.

# Overpressure indicators

Overpressure indicators on progressive feeders make it easier to localize malfunctions when they occur. They are screwed into the upper alternative outlet ports. If the specified lubricant pressure is exceeded in an outlet port equipped with an overpressure indicator, a pin emerges from the front of the indicator, thus pointing out the overpressure. After the fault is remedied, the pin has to be pressed in again by hand.

Table 5

Rated pressure [bar]	Order No. with Whitworth tubing threads	d
16	<b>VPG-UE16-2</b>	G1/8A
32	<b>VPG-UE32-2</b>	G1/8A
63	<b>VPG-UE63-2</b>	G1/8A
80	<b>VPG-UE80-2</b>	G1/8A
100	<b>VPG-UE100-2</b>	G1/8A
140	<b>VPG-UE140-2</b>	G1/8A
180	<b>VPG-UE180-2</b>	G1/8A

Table 6

Rated pressure [bar]	Order No. with metric threads	d	Order No. with Whitworth tubing threads	d
50	<b>VPM-UE50-3</b>	M10x1	<b>VPG-UE50-3</b>	G1/8A
100	<b>VPM-UE100-3</b>	M10x1	<b>VPG-UE100-3</b>	G1/8A
150	<b>VPM-UE150-3</b>	M10x1	<b>VPG-UE150-3</b>	G1/8A
200	<b>VPM-UE200-3</b>	M10x1	<b>VPG-UE200-3</b>	G1/8A

VP /VPG-...-2

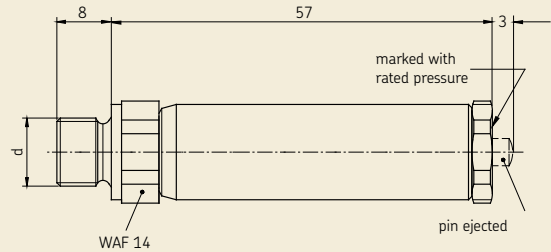

VPM /VPG-...-3

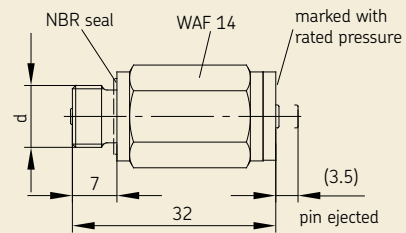

# Rupture discs

Table 7

Order No.	Rupture pressure [bar]	Color	Thickness [mm]
<b>PPU-BS60</b>	60	black	0,152
<b>PPU-BS80</b>	80	green	0,203
<b>PPU-BS100</b>	100	yellow	0,254
<b>PPU-BS120</b>	120	red	0,305
<b>PPU-BS140</b>	140	orange	0,356
<b>PPU-BS160</b>	160	silver	0,406
<b>PPU-BS180</b>	180	pink	0,457

# Retainer for burst discs

Retainer PPU-SH

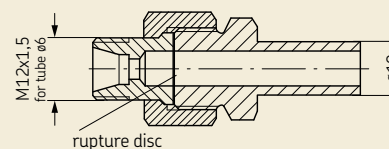
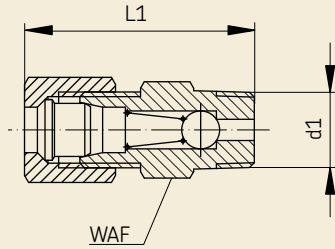

Table 8

Order No.	for tube diam.	Version
<b>PPU-SH</b>	10	<b>with tube neck for cutting sleeve screw union</b>

# Check valves

VPG / VPKG / VPKM / VPM



VPKG-...-VS / VPKM-...-VS

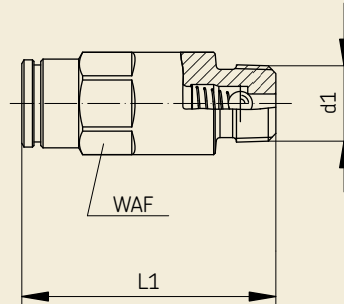
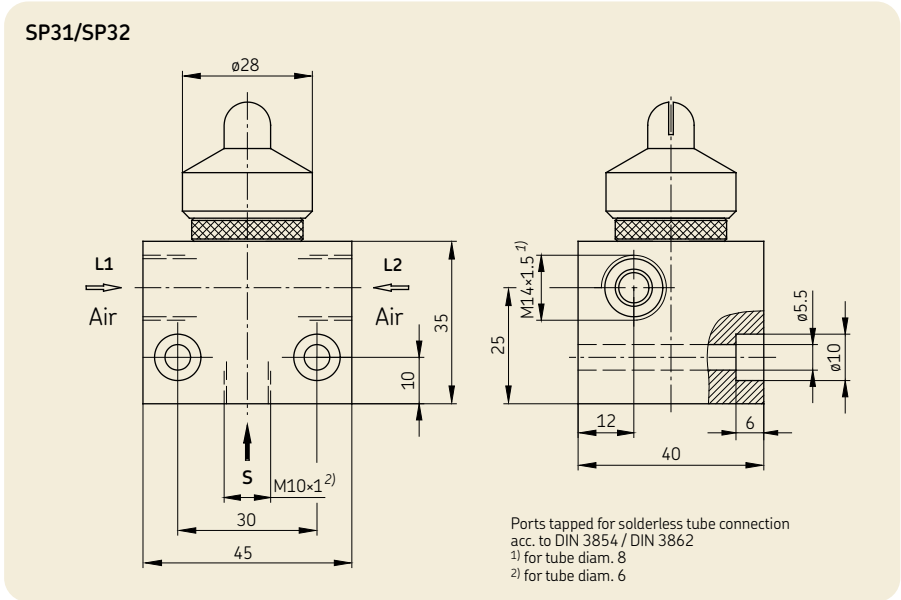

Table 9

Order No	Screw in thread d1	Tube diameter	Opening pressure [bar]	PN [bar]	SW	Length L1	Information
VPG-RV	R 1/8 keg	4 (LL)	10	100	12	23	–
VPG-RV6	R 1/8 keg	6 (L)	10	315	14	25	–
VPG-RV8	R 1/8 keg	8 (L)	10	315	14	25	–
VPKG-RV	R 1/8 keg	6 (LL)	3	100	12	29,5	with sleeve and socket union
VPKG-RV-VS	R 1/8 keg	6	3	300	12	33,5	with SKF Quick Connector
VPKM-RV-S3	M 10x1 keg	6 (LL)	3	100	12	29,5	Stainless steel, with sleeve and socket union
VPKM-RV-S4	M 10x1 keg	6 (LL)	2	100	11	30,3	with sleeve and socket union
VPKM-RV-VS	M 10x1 keg	6	3	300	12	33,5	with SKF Quick Connector
VPM-RV	M 10x1 keg	6 (L)	10	315	14	25	–
VPM-RV10	M 10x1 keg	10 (L)	10	315	17	26	–
VPM-RV4	M 10x1 keg	4 (LL)	10	100	12	23	–
VPM-RV8	M 10x1 keg	8 (L)	10	315	14	25	–



# Spray nozzles for grease up to NLGI grade 2



These spray nozzles are used to spray grease up to NLGI grade 2 on surfaces, e.g. on the tooth surface of large gears.

## Function

The grease is supplied by pulsation via inlet S by, for instance, a progressive feeder and is blown out by compressed air flowing continuously during the entire lubrication period. Compressed air is connected to inlet L1, optionally to L2. Depending on the construction of the spray nozzle, the spray pattern is either rectangular (SP31) or circular (SP32).

Several spray nozzles may be connected in series to one compressed air line. At the last spray nozzle of one line, however, one inlet borehole for the compressed air must be closed with a screw plug. This also applies where there is only one spray nozzle.

## Technical data

Order No. . . . . . **SP31**  
 Spray pattern . . . . . rectangular  
 Order No. . . . . . **SP32**  
 Spray pattern . . . . . circular  
 Lubricant . . . . . Grease up to NLGI-Grade. 2

Air pressure . . . . . 5 bars min.  
 Air flow rate with 5 bars . . . . . 7 Nm<sup>3</sup>/h  
 Spraying distance . . . approx. 300 mm

Sprayed surface at a distance of 100 mm:  
 SP31 . . . . . approx. 50x220 mm  
 SP32 . . . . . approx. 45 mm

# Pressure relief valve (PRV)



In order to prevent an excessive operating pressure in a lubrication system, a pivoted pressure relief valve should be attached. If the operating pressure exceeds the cracking pressure of the pressure relief valve, then the valve will open and the lubricant can escape. One can select among the following variants:

- PRV with T-fitting
- PRV with lubricating nipple
- PRV with switch
- PRV with lubricating nipple and SKF Quick Connector
- PRV with elbow fitting

## PRV with T-fitting

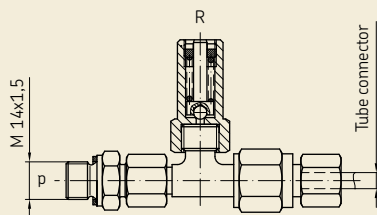

## PRV with lubricating nipple

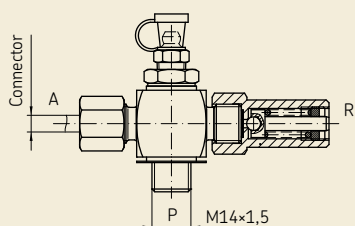

## PRV with switch

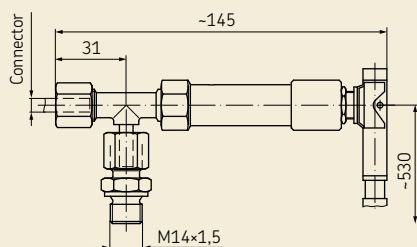

## PRV with lubricating nipple and SKF Quick Connector

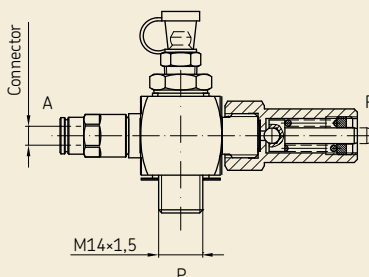

## PRV with elbow fitting

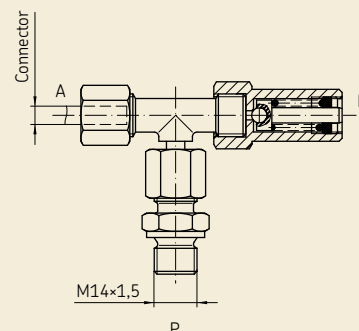

Table 10

Order number	Type	Opening pressure [bar]	Tube diameter [mm]
161-210-016	PRV with T-fitting	300	10
161-210-039	PRV with T-fitting	300	8
161-210-038	PRV with T-fitting	300	6
161-210-030	PRV with T-fitting	200	10
161-210-031	PRV with T-fitting	200	8
161-210-032	PRV with T-fitting	200	6
161-210-040	PRV with T-fitting	120	10
161-210-041	PRV with T-fitting	120	8
161-210-042	PRV with T-fitting	120	6
161-210-014	PRV with lubricating nipple	300	6
161-210-025	PRV with lubricating nipple	300	8
169-200-130	PRV with switch	250	6
161-210-020	PRV with lubricating nipple und SKF Quick Connector	300	6
161-210-022	PRV with lubricating nipple und SKF Quick Connector	300	8
161-210-006	PRV with elbow fitting	300	6
161-210-018	PRV with elbow fitting	300	8
161-210-035	PRV with elbow fitting	300	10
161-210-049	PRV with elbow fitting	200	6
161-210-050	PRV with elbow fitting	200	8
161-210-051	PRV with elbow fitting	200	10



**!** **Important information on product usage**

SKF and Lincoln lubrication systems or their components are not approved for use with gases, liquefied gases, pressurized gases in solution and fluids with a vapor pressure exceeding normal atmospheric pressure (1.013 mbar) by more than 0,5 bar at their maximum permissible temperature.

**Additional brochures for further information:**

1-0103-DE *Fittings and Accessories*

1-9201-DE *Transport of Lubricants in Centralized Lubrication Systems*

**SKF Lubrication Systems Germany GmbH**

Berlin Plant  
Motzener Str. 35/37 · 12277 Berlin  
PO Box 970444 · 12704 Berlin · Germany

Tel. +49 (0)30 72002-0  
Fax +49 (0)30 72002-111

**This brochure was presented to you by:**

© SKF is a registered trademarks of the SKF Group.

© SKF Group 2021

The contents of this publication are the copyright of the publisher and may not be reproduced (even extracts) unless prior written permission is granted. Every care has been taken to ensure the accuracy of the information contained in this publication but no liability can be accepted for any loss or damage whether direct, indirect or consequential arising out of the use of the information contained herein.

PUB LS/P2 12005 EN · April 2021 · 1-0107-6-EN

